

THE HORIZONTAL TAP ADAPTER (HTA) IS SHOWN INSTALLED ON AN A-32 TAPPING ARM. THE HORIZONTAL TAP ADAPTER CAN BE INSTALLED ON A-32, S-36 AND M-60 TAPPING ARMS AS WELL AS S-36 AND M-60 DIE GRINDER ARMS.

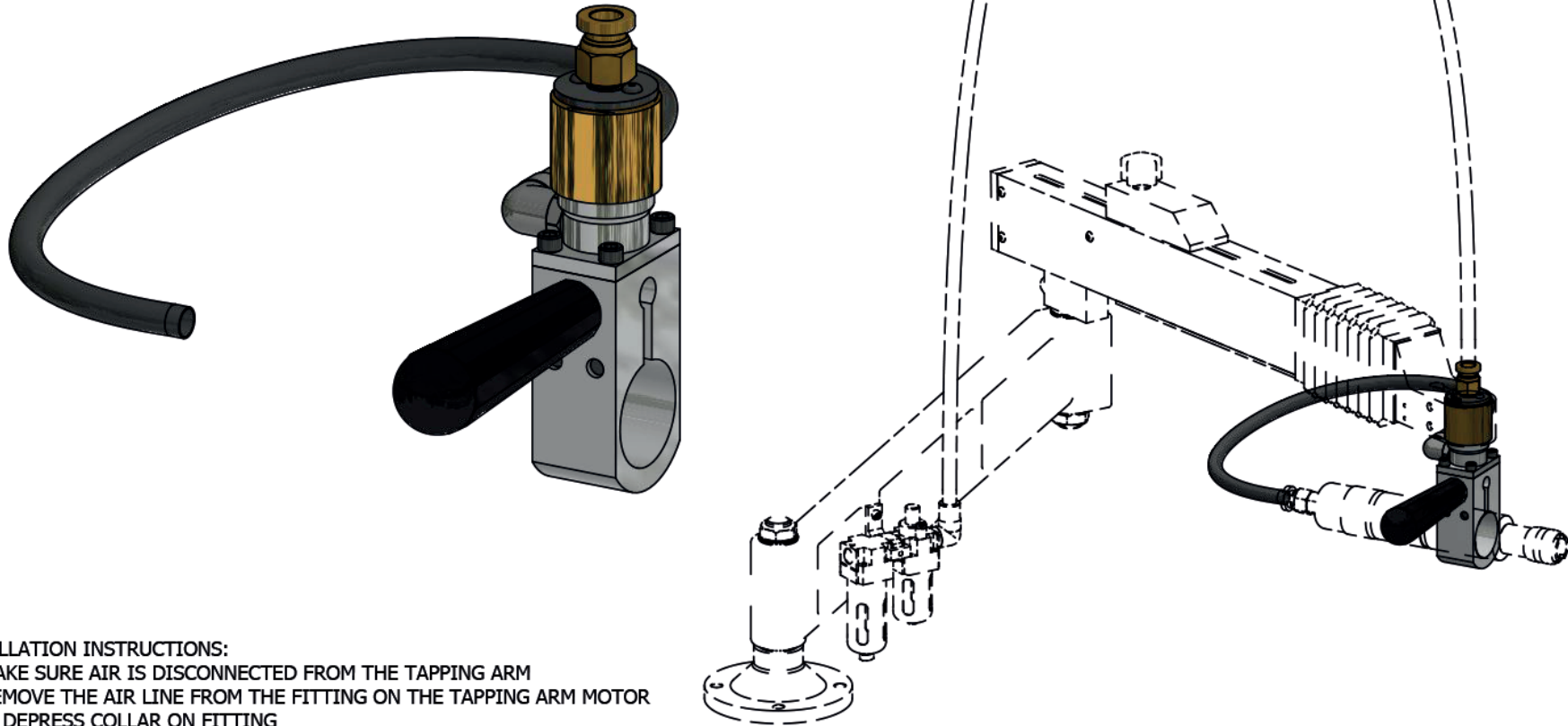

INSTALLATION INSTRUCTIONS:

1. MAKE SURE AIR IS DISCONNECTED FROM THE TAPPING ARM
2. REMOVE THE AIR LINE FROM THE FITTING ON THE TAPPING ARM MOTOR
 - a. DEPRESS COLLAR ON FITTING
 - b. WITH COLLAR DEPRESSED, PULL AIR LINE OUT OF FITTING
3. REMOVE THE TWO SOCKET HEAD CAP SCREWS (SHCS) FROM THE MOTOR MOUNT CLAMP
4. REMOVE THE MOTOR BY PULLING IT UP & OUT OF THE MOTOR CLAMP
5. INSERT THE HORIZONTAL TAP ADAPTER (HTA) UP THROUGH THE BOTTOM OF THE MOTOR MOUNT CLAMP
6. ALIGN THE GROOVES IN THE HTA WITH THE TWO MOTOR MOUNT CLAMP BOLT HOLES
7. INSTALL THE TWO SHCS IN THE MOTOR MOUNT CLAMP (DO NOT OVERTIGHTEN)
8. REMOVE THE TWO (SHCS) FROM THE HTA CLAMP
9. INSERT THE MOTOR IN THE HTA CLAMP
10. ALIGN THE GROOVES IN THE MOTOR WITH THE TWO HTA CLAMP BOLT HOLES
11. INSTALL THE TWO SHCS IN THE HTA CLAMP (DO NOT OVERTIGHTEN)
12. INSERT THE TAPPING ARM AIR HOSE IN THE TOP FITTING OF THE HTA
13. INSERT THE HTA AIR HOSE IN THE MOTORS AIR FITTING
14. RECONNECT AIR SUPPLY TO THE TAPPING ARM